



AIR 40A
600Hz 2-6S NO BEC



FEATURES:

1. Special core program for multi-rotor controllers greatly improves throttle response.
2. Specially optimized firmware for excellent compatibility with disc-type motors.
3. All settings except the timing are preset, making usage simple, highly intelligent and adaptive.
4. The twisted-pair design of the throttle signal cable effectively reduces the crosstalk produced in signal transmission and makes flight more stable.
5. Compatible with various flight-control systems and supports a signal frequency of up to 621Hz. (Note: all throttle signals over 500Hz are non-standard signals) .
6. Perfect combination with T-MOTOR brand motor Makes even better performance.

SPECIFICATIONS

Model	Con,Current	Peak Current (10S)	BEC	Lipo	programmable Item	Weight	Size(l*W*H)
AIR 40A	40A	60A	NO	2-6S	Timing (Intermediate/High)	26g	55.6*25.2*11.3mm

USER GUIDE

Throttle Calibration & ESC Programming

* Users need to calibrate the throttle range when they start to use a new AIR brushless ESC or another transmitter.

* Users can change the Timing setting when some abnormality occurs in the ESC driving the disc-type motor or need the motor to reach a higher RPM. (Note: Intermediate Timing is the default setting.)

STEP 1: MOTOR WIRING

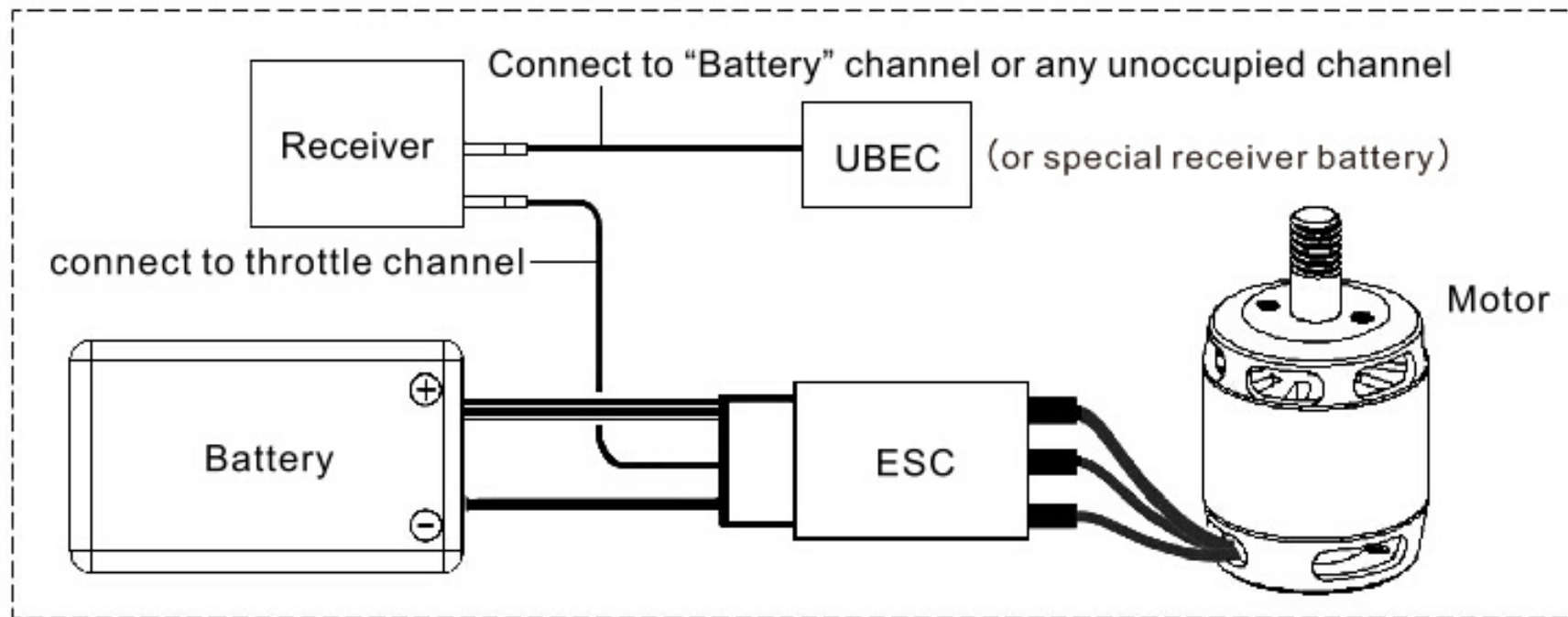

Cautions: Pay attention to the Positive and Negative Poles when you are making connection to the motors and the ESCs. False connection will definitely damage the products.

STEP 2: THROTTLE RANGE CALIBRATION

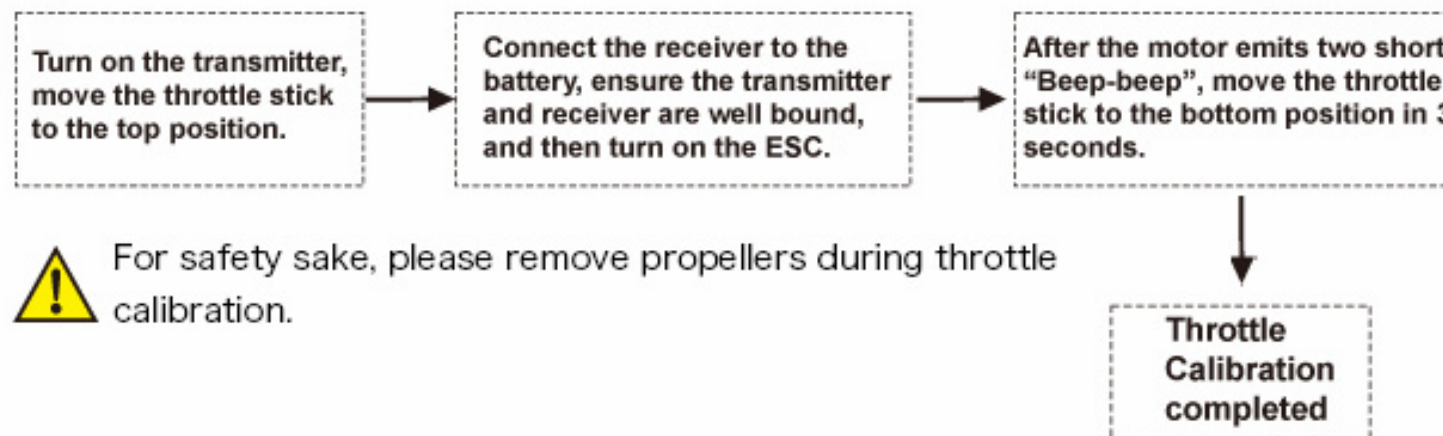

For safety sake, please remove propellers during throttle calibration.

STEP 3: ESC PROGRAMMING

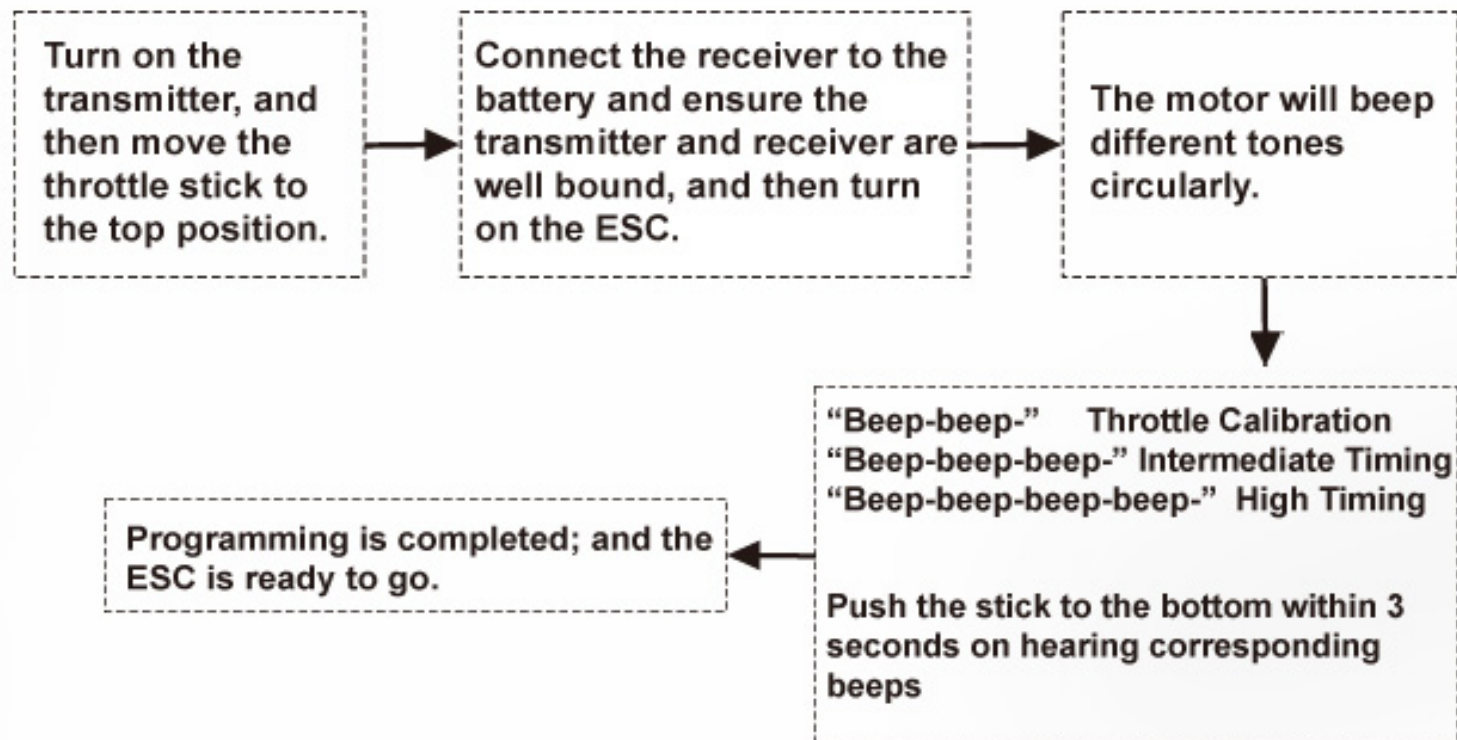

Notes: Generally speaking, intermediate timing is applicable to most motors and it brings higher efficiency but less heat to the motors and speed controllers. High timing can increase the RPM of the motor, but it also increases the motor temperature. Please perform a test flight on the ground and ensure everything is functioning properly first, then fly your aircraft into the sky.

NORMAL START-UP PROCESS

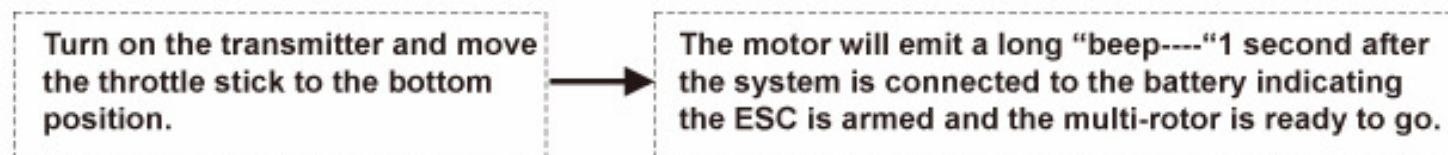

PROTECTIONS

Start-up Protection: The ESC will shut down the motor if it fails to start the motor normally within 2 seconds by increasing the throttle value. In this case, you need to move the transmitter throttle stick back to the bottom position and restart the motor. (Possible causes of this problem: poor connection/disconnection between the ESC and motor wires, propellers are blocked, etc.)

Over-load Protection: The ESC will cut off the power/output when the load suddenly increases to a very high value. Normal operation will not resume until the throttle stick is moved back to the neutral position. The ESC will automatically attempt to restart when the motor and the ESC are out of sync.

Throttle Signal Loss Protection: When the ESC detects loss of signal for over 0.25 second, it will cut off the output immediately to avoid an even greater loss which may be caused by the continuous high-speed rotation of propellers or rotor blades. The ESC will resume the corresponding output after normal signals are received.

TROUBLESHOOTING

Trouble	Warning Tone	Possible Cause	Solution
The ESC was unable to start the motor.	"Beep beep beep..." (The motor beeps rapidly)	The throttle stick is not at the bottom position.	Move the throttle stick to the bottom position or recalibrate the throttle range.
The ESC was unable to start the motor.	"Beep, beep, beep....." (Time interval is 1 second)	No output signal from the throttle channel on the receiver.	Check if the transmitter and receiver are well bound; Check if the throttle wire has been properly plugged into the throttle channel on the receiver.
The ESC was unable to start the motor.	"BB, BBB, BBBB" (these tones are played circularly)	The "Normal /Reverse" direction of the throttle channel on transmitter is incorrect.	Refer to the transmitter instructions and correctly set the "Normal/ Reverse" direction of the throttle channel.